

## Innovative Deterministic Seakeeping Test Procedures

Janou Hennig  
Berlin University of  
Technology  
[Hennig@ism.tu-berlin.de](mailto:Hennig@ism.tu-berlin.de)

K.-E. Brink  
HSVA, Hamburg Ship Model  
Basin  
[Brink@hsva.de](mailto:Brink@hsva.de)

Walter L. Kuehnlein  
HSVA, Hamburg Ship Model  
Basin  
[Kuehnlein@hsva.de](mailto:Kuehnlein@hsva.de)

### ABSTRACT

At present common stability criteria are based on practical knowledge gained from the operation of ships. Therewith the assessment of ship safety against capsizing is partly determined by long-term statistics of accidents. Regulations like the IMO-Resolution A 167 do not rate the typical seakeeping characteristics of different hull form geometries. Therefore strictly speaking, these criteria are just applicable for ships of similar types as included in statistics. Rapid development in ship design calls for the determination of ship and cargo safety in regard of extreme roll motions or capsizing during early design stage.

Within the ROLL-S project, which was founded by the German Federal Ministry of Education and Research, dynamic stability tests with a box shaped Container Ship and a RO-RO vessel have been performed. The performance of model tests, which are intended to serve for the validation of numerical simulation methods, put high demands on test and data acquisition techniques. The data of the waves encountered, course and position, as well as the response of the model had to be determined by model tests in order to use these data for the validation of numerical ship motion simulations.

During the tests extreme roll motions of the two considered vessels could be observed in head seas and in following seas. Besides critical motion characteristics in following seas, like broaching, the model had to be determined by model tests in order to use these data for the validation of numerical ship motion simulations

Remark: This paper should be read in conjunction with paper No. 25 of STAB 2003 the model had to be determined by model tests in order to use these data for the validation of numerical ship motion simulations.

### KEYWORDS:

100% computer controlled dynamic stability tests, reproducible model tests, deterministic model test procedure, deterministic freak waves, transient wave packets.

## INTRODUCTION

Within the German BMBF-funded Joint Research Project ROLL-S the Hamburg Ship Model Basin performed model tests in order to provide data for the validation of numerical simulation tools for the prediction of extreme roll motions up to capsizing.

Common stability criteria in use are based on practical knowledge gained from the operation of ships. Therewith the assessment of ship safety against capsizing is partly determined by long-term statistics of accidents. Regulations like IMO-Resolution A 167 which is still valid today, do not rate the typical seakeeping characteristics of different hull form geometries. Therefore, in a strict sense, these criteria are just applicable for ships, which are similar to the types of vessels included in the statistics.

Rapid development in ship design requires the determination of ship and cargo safety in respect of extreme roll motions or capsizing during the early design stage. It is intended to solve this problem with numerical simulations of ship motions considering any hull form geometry of interest.

Thereby model test results will serve as a validation for existing theoretical methods, which will be further improved in the future.

Dynamic stability tests with a box shaped Container Ship and a RoRo vessel have been performed within the ROLL-S project in regular waves and irregular seaways with/without integrated wave packets (freak waves) in order to provide data for the validation of numerical simulation tools. The present paper gives a short description of the applied model test technique and some test results.

## NOMENCLATURE

GM	Metacentric Height
L <sub>pp</sub>	Length between perpendiculars
n	Propelling rate
t	Time

$T_e$	Period of encounter
$T_\Phi$	Natural roll period of the ship
v	Main-carriage speed or ship speed
x	Main-carriage position
y	Transversal model position
$y_{SC}$	Transversal sub-carriage position
z	Heave motion
$\delta$	Rudder angle
$\Delta x$	Longitudinal model position relative subcarriage
$\Delta y$	Transversal model position relative subcarriage
$\Phi$	Roll angle
$\lambda$	Regular wave length
$\mu$	Relative course angle
$\Theta$	Pitch angle
$\Psi$	Yaw angle
$\zeta_{AMS}$	Wave amplitude at midship section
$\zeta_w$	Wave height
$\zeta_{w\ sig}$	Significant wave height

## ADVANCED HSVA MODEL TESTING TECHNIQUE

Various seakeeping and capsizing tests have been performed at HSVA in the past. Self propelled, free running models were hand operated by a helmsman accommodated on a sub-carriage.

As a result of this former test procedure time histories of different ship motions have been determined. Because of the impossibility of wave measurements at the position of the model, the ship motions could not be related to the actual waves encountered. This imperfection was of minor interest for former investigations as the safety of ships against capsizing was determined for seaways which had been described by their statistical properties.

This paper describes the testing technique, which has been developed during the research project ROLL-S (see Fig. 1). Reproducible model scale seaways were described and measured in a first series of tests as a function of time and place in

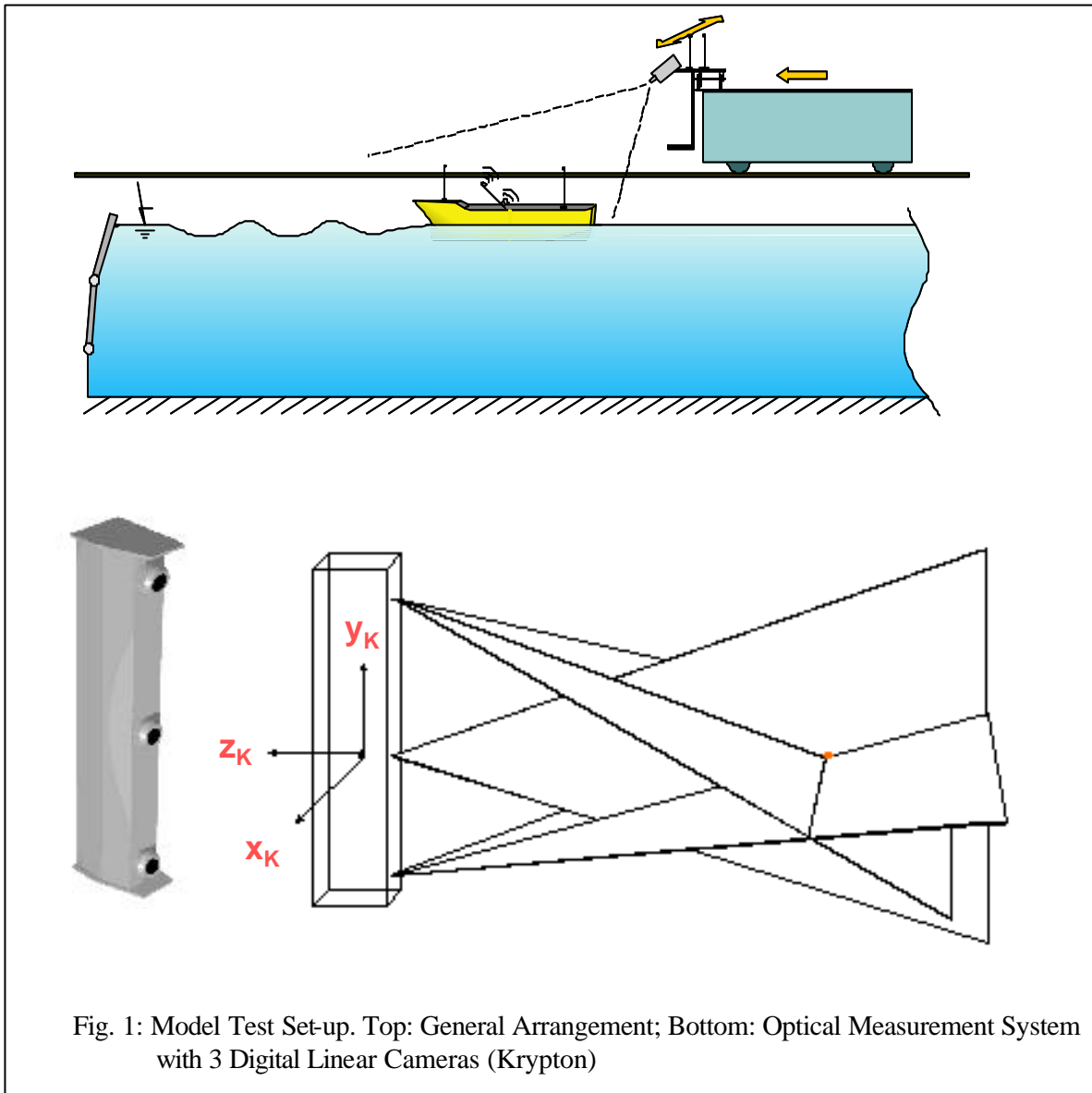

Fig. 1: Model Test Set-up. Top: General Arrangement; Bottom: Optical Measurement System with 3 Digital Linear Cameras (Krypton)

the model basin. During subsequent tests the position of the model in the tank and its actual orientation in six degrees of freedom was determined

as a function of time as well. Finally the time histories of the seaways and time histories of related ship motions were matched over time and location in the tank. This part of the project was performed by the Ocean Engineering Section of the University of Berlin, (Clauss, G. and Hennig, J., 2003).

The performance of model tests, which are intended to serve for the validation of numerical simulation methods, put high demands on the used test and data acquisition techniques.

The ROLL-S model tests procedure fulfils the following requirements:

**Computer controlled test runs.**

In order to perform accurate, reproducible model tests each single test run is completely computer controlled including the rudder of the model. The main objective of the computer control lies in the

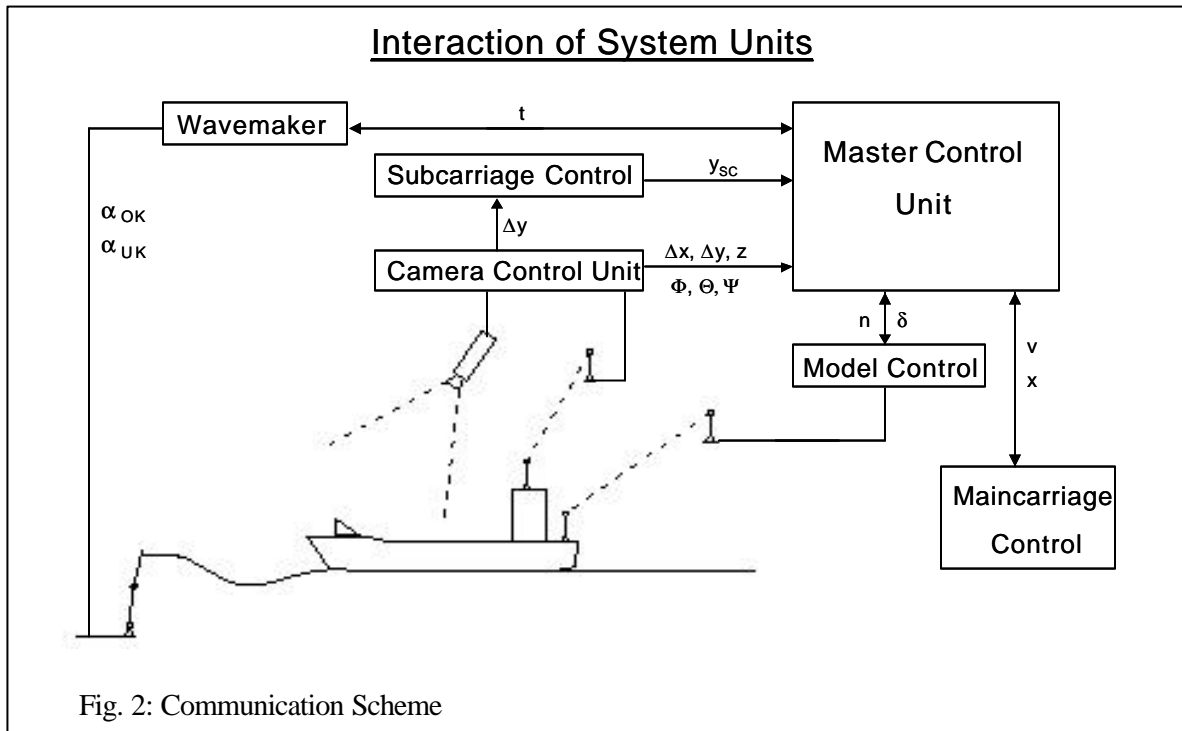

temporal co-ordination between wave maker and model ride, the piloting of the model and the control of main-carriage and subcarriage. Please note that the model meets the waves at a predestined location and time with an also predestined course and speed. And all these tests are 100% reproducible.

**Investigation of radio controlled free running models without any connecting cables**

The two different models in consideration, made of GRP, were equipped with watertight decks and simplified superstructure. During the tests the models were fitted out with a propelling motor, a rudder machine and batteries as a power supply. In absence of any connecting cables the models are completely free in their motions.

With the use of an internal hoist, ballast weights could easily be moved in order to change the metacentric height of the models.

**Use of a contactless measurement system for the determination of model position and orientation**

A camera-based system measures the model position and orientation in six degrees of freedom in relation to the sub-carriage. The contactless measurement system includes a camera unit consisting of three linear cameras, which are located on the sub-carriage (see Fig. 1, bottom). Therewith X, Y and Z co-ordinates of model fixed IR LED's are measured at high resolution in real time.

Three LEDs are connected together on a model fixed rigid body frame, which enables not only the measurement of the model position, but also the determination of the model orientation. With the known sub-carriage position in the tank and the position of the model relative to the sub-carriage, the model position in the tank can easily be determined. The camera unit and the model fixed LEDs are radio controlled.

### **Precise measurement of main-carriage and sub-carriage position and speed**

In order to allow a synchronisation of the seaway data measured in advance of the model tests and the time histories of the model's motion behaviour, the position of the main- and subcarriage has to be measured accurately during the model tests.

Thereby the absolute position of the carriage is set by non-contact switches before the measurement is started. During the tests the actual position of the carriage is determined with the help of the carriage speed. As the model position relative to the carriage is known, its absolute position in the tank is known at any time. Therewith the model response can exactly be related to the belonging data of the seaway.

### **An integrated data acquisition system, which connects the different system components**

During test runs the master control unit has the temporal control on the double-flap-wavemaker (time  $t$ ), is piloting the model (propeller rate  $n$ , rudder angle  $\delta$ ) and drives the main-carriage (speed  $v$ , position  $x$ ). Meanwhile the camera control unit is evaluating the longitudinal and lateral position of the model relative to the sub-carriage ( $\Delta x, \Delta y$ ), the heave motion ( $z$ ) and the roll, pitch and yaw angles of the model ( $\Phi, \Theta, \Psi$ ). During the tests the sub-carriage position ( $y_{SC}$ ) is controlled by the lateral position of the model relative to the sub-carriage.

Figure 2 illustrates the communication scheme of the system, which integrates all different components.

## **WAVE GENERATION AND REPRESENTATION**

Software tools for the wave generation were developed by the Institute of Naval Architecture and Ocean Engineering, (ISM), Berlin University of Technology. Due to the requirements of the

different joint research project members, dynamic stability tests have been performed in different types of waves. They can be described as follows:

- Steep regular waves with wave length of  $\lambda \approx 0.8 \cdot L_{pp}$ ,  $1.1 \cdot L_{pp}$  and  $1.4 \cdot L_{pp}$
- Irregular long crested seaways with JONSWAP Standard Spectrum
- Transient wave groups
- Regular waves and irregular seaways with integrated transient wave trains (freak waves).

The performance of model tests in regular waves and irregular seaways are common practice. However the deterministic model testing process within the ROLL-S project allowed the application of transient wave groups. Thereby high wave groups are generated in such a manner that they concentrate at a selected position in a deterministic freak wave.

It has to be pointed out that with each start of the wavemaker realisations of identical control signals and therewith reproducible wave groups and seaways were generated. As mentioned before, the wave elevations of the different types of waves have been measured in absence of the model during a first series of tests. For this purpose various wave probes have been installed in the tank at fixed positions at a distance between 80 m and 140 m from the wavemaker and also at the carriage.

From these measurements time histories of the wave elevation at different positions in the tank were derived. Therewith the wave geometry encountered during a subsequent test could be determined as a function of actual model position and time.

## **INVESTIGATED MODELS**

A total number of about 180 test runs has been conducted with the model of a box shaped container ship, built to a scale of 1:29, and the model of a Ro/Ro vessel, built to a scale of 1:34.

Body plans and main dimensions of both ships are given in Figure 3.

The hull form geometry of the bulbless container vessel is characterised by a full rectangular midship section with small bilge keel radius, rather steep V-shaped forebody sections and a slightly immersed transom. The investigated Ro/Ro vessel features relatively large deck areas and therewith a considerable bow flare, a large bilge radius and wide, flat stern overhangs.

Due to the characteristic hull form geometries of the ships in consideration, large variations in righting levers have to be expected for the Ro/Ro vessel.

and stern waves with a length similar to the ship length when the relative motion at bow and stern gets large, only tests in head to head quartering seas ( $\mu = 180^\circ$  to  $150^\circ$ ) and stern-to-stern quartering seas ( $\mu = 0^\circ$  to  $30^\circ$ ) were conducted.

During the test series in regular waves wave length, the metacentric height of the model and the model speed were varied in order to adjust the period of encounter ( $T_e$ ) to be equal to half of the natural roll period of the ship ( $T_\phi$ ) or equal to the natural roll period itself.

Thereby it may be pointed out that the number of model test conditions, which will lead to severely parametrically induced roll motions, is restricted

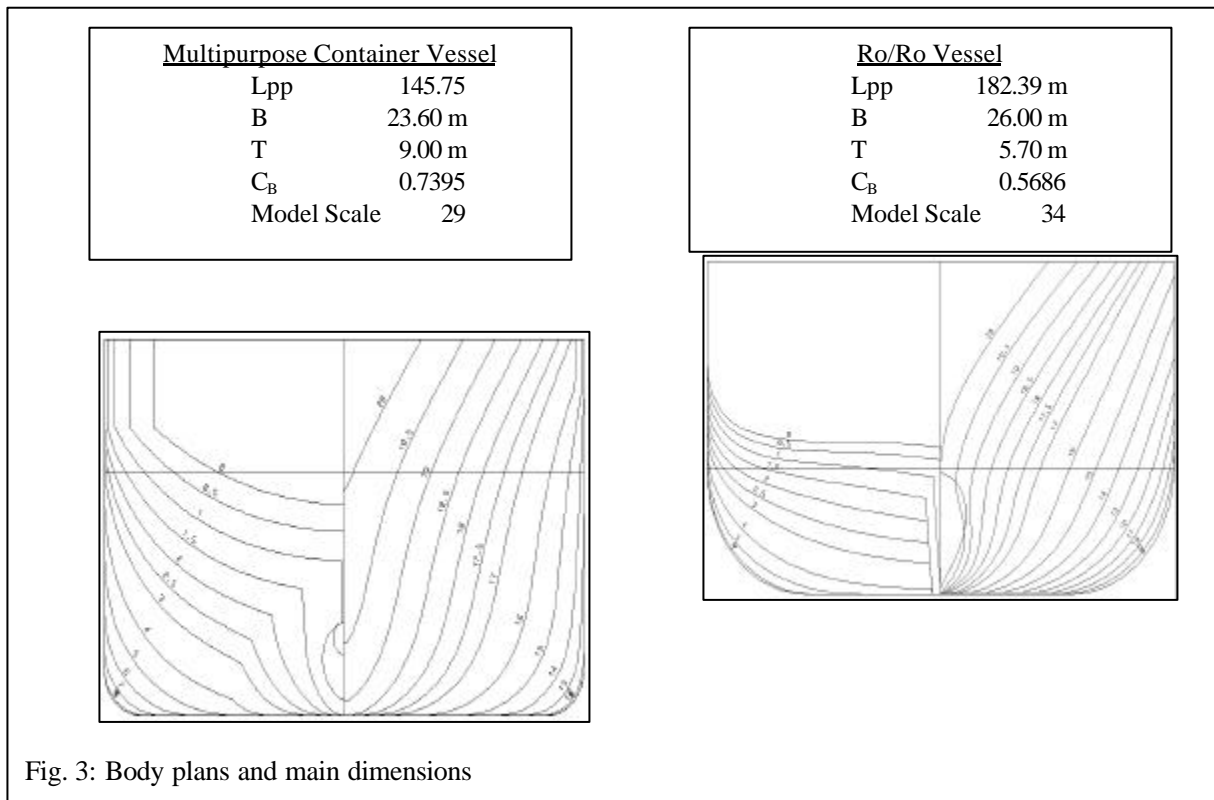

## TEST CONDITIONS

Model tests in regular waves have been performed with the intention to generate parametrically induced roll motions, which are caused by the variation of righting levers in waves. As the variation is maximised in head

due to the following facts:

- Only a small range of wavelength to ship length ratios will cause large relative motions at bow and stern and therewith lead to considerable variations in righting levers.
- Only low GM-values (long natural roll motion periods) promote the occurrence of severe parametrically induced roll motions, as the righting lever variation has to be

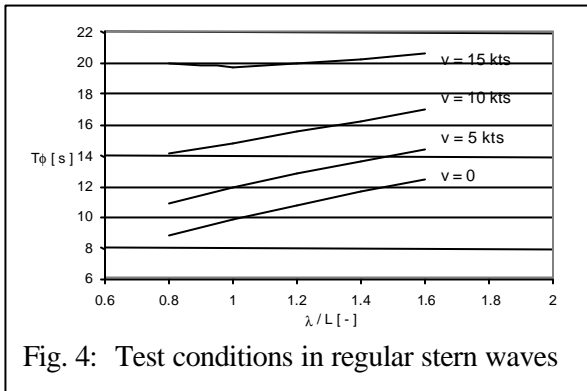

Fig. 4: Test conditions in regular stern waves

relatively large compared to the calm water righting lever arm.

- Only a restricted speed range can be investigated. On the one hand a sufficient ahead speed is required during the tests to assure the ability to keep the selected course, on the other hand the natural roll damping of ships strongly increases with speed, which makes the occurrence of large rolling angles less favourable.

Test conditions in stern seas have been calculated exemplarily for the full-scale ship resulting in similarity of the periods of encounter and the natural roll motion period of the container vessel investigated. The results are shown in Figure 4 for different ship speeds as a function of the ratio of wavelength to ship length.

## RESULTS

The motion behaviour of different ship models in response to the actual wave pattern encountered has been determined. The results are given in form of time histories as a function of place or time.

Exemplary results of two single test runs with the model of the Ro-Ro vessel are presented here.

In Figure 5 characteristic motions and the actual wave pattern are given for the model running at about 15 knots in irregular following seas with a superimposed transient wave train. Three diagrams can be found in Figure 5. The

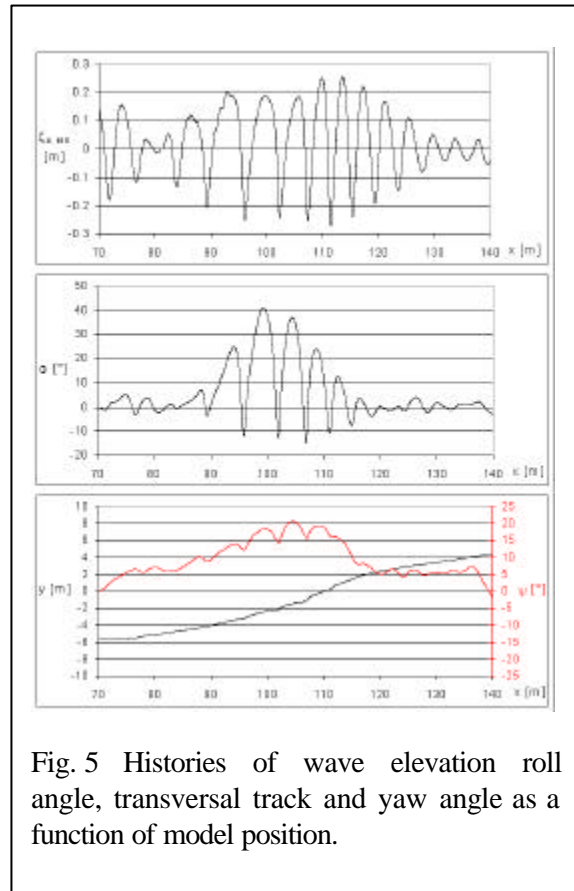

Fig. 5 Histories of wave elevation roll angle, transversal track and yaw angle as a function of model position.

uppermost diagram contains the wave amplitude at the midship section of the model ( $\zeta_{\lambda MS}$ ) whereas the diagram underneath shows the corresponding roll angle ( $\Phi$ ). In the last diagram the transversal track ( $y$ ) and the yaw angle ( $\Psi$ ) of the model can be found. (Full scale test conditions:  $GM = 1.36$  m, Relative course angle  $\mu = 10^\circ$ , Maximum wave height of the irregular seaway  $\zeta_{w sig} = 15.3$  m)

In a second set of diagrams model test results are given which have been derived from a test in regular head waves. Besides the wave amplitude at the midship section of the model ( $\zeta_{\lambda MS}$ ) the corresponding roll angle ( $\Phi$ ) and the pitch angle ( $\Theta$ ) can be found in Figure 6. (Full scale test conditions:

$v = 10.2$  kts,  $GM = 1.36$  m, Relative course angle  $\mu = 175^\circ$ , parameter of the regular waves  $\lambda/L_{pp} = 1.2$ ,  $\zeta_w^? = 5.1$  m)

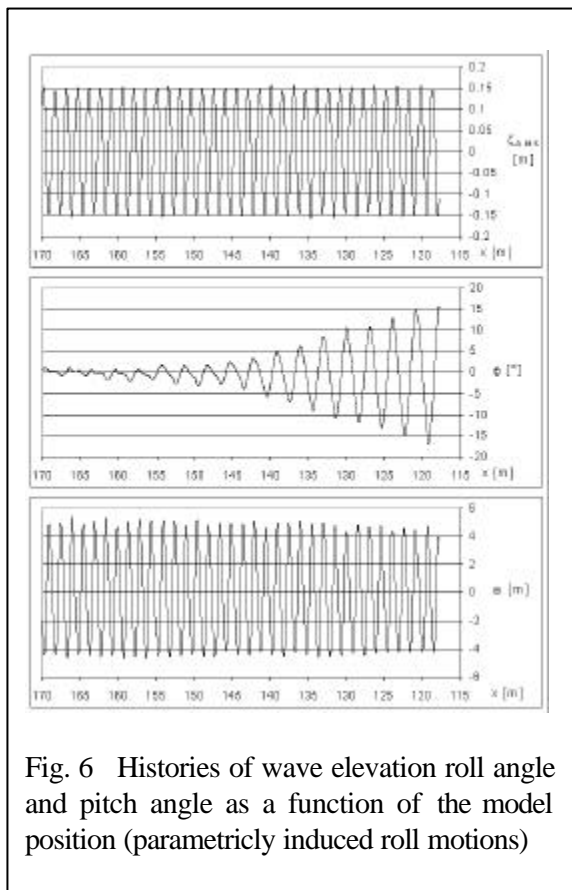

Fig. 6 Histories of wave elevation roll angle and pitch angle as a function of the model position (parametrically induced roll motions)

Figure 6 illustrates the development of parameter induced roll motions. The subject of parametric roll on ships is of great interest as designers increasingly push the envelope of established design practices. Parametrically induced roll motions are a nonlinear phenomenon that can cause large roll motions that are coupled with large pitch motions when a ship is at or near head sea conditions. Parametrically induced roll motions in head seas can occur if unfavourable turning is combined with large stability variations, particularly on vessels with extensive bow flare and broad counter sterns. These characteristics may be especially true for modern containerships, cruise ships, and other large displacement vessels, which have large bow flare and broad counter sterns for increasing the deck and stowage area.

## CONCLUSIONS

Within the BMBF-funded joint research project ROLL-S seakeeping tests with models of a container ship and a RoRo-vessel were conducted in order to provide data for the validation of numerical ship motion simulation tools. With the help of improved testing techniques ship motions in different seaways have been investigated accurately, mainly with respect to large roll angles. Several test conditions led to severe rolling (exceeding roll motion amplitudes of 35°) or even capsizing of the models.

## ACKNOWLEDGMENTS

Within this project the Institute of Naval Architecture and Ocean Engineering, Technical University of Berlin (ISM) developed software tools for the generation of waves. The deterministic model testing process within the ROLL-S project allows the application of transient wave groups including their integration into irregular sea states, where they are generated in such a manner that they concentrate at selected positions in deterministic freak waves.

The authors also wish to thank the German Federal Ministry of Education, Research and Development (BMBF) for the foundation of the research project: ROLL-S.

## REFERENCES

- Clauss, G. and Hennig, J: Computer Controlled Capsizing Tests using Tailored Wave Sequences, Proceedings of International Conference on the Stability of Ships and Ocean Vehicles. STAB 2003, Paper No. 25, September 15-19, 2003, Madrid, Spain.
- Clauss, G. and. Kuehnlein, W.L.: Simulation of design storm wave conditions with tailored wave groups. Discussion on the Report of Seakeeping Committee --- 21<sup>st</sup> International Towing Tank

Conference, Vol. 2, pages 203-205, September 15-21, 1996, Trondheim, Norway

Clauss, G. and. Kuehnlein, W.L.: Transient wave packets - an efficient technique for seakeeping tests of self-propelled models in oblique waves. Third International Conference on Fast Sea Transportation, pages 1193-1204, Vol. 2, September 1995, Lübeck-Travemünde, Germany.

Nattero, M., Blume, P.: Survivability tests with a damaged RoRo passenger vessel according to the new IMO-regulations and further activities planned by CONFITARMA and HSVA. Proceedings of RORO'96, May 1996, Lübeck, Germany