

Solar-array controller needs no multiplier to maximize power

Relying on the logarithmic behavior of transistor junctions to calculate power, this controller operates a photovoltaic array at its maximum power point.

W Stephen Woodward (<http://www.edn.com/article/CA6619019.html?nid=4173>)

Solar-voltaic arrays are among the most efficient, cost-effective, and scalable “green” alternatives to fossil fuels, and researchers are almost daily announcing new advances in photovoltaic technology. But successful application of photovoltaics still depends on strict attention to power-conversion efficiency. Figure 1 shows one reason for this attention.

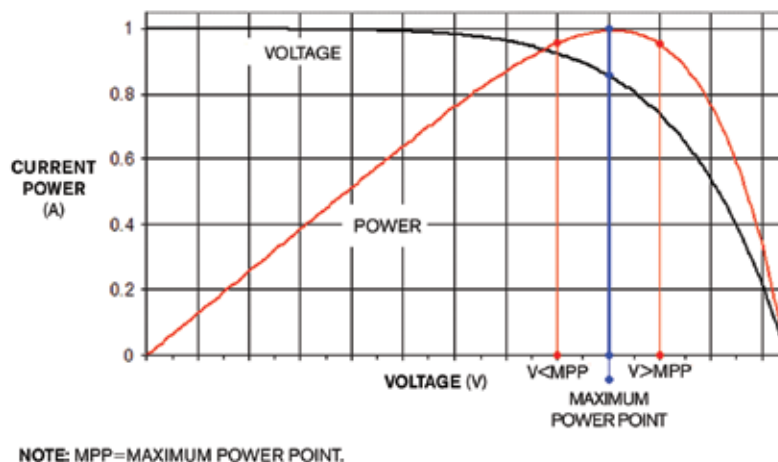

Figure one. It is important to operate solar-photovoltaic arrays at their maximum power point.

A photovoltaic array’s delivery of useful power to the load is a sensitive function of load-line voltage, which in turn depends on insolation—that is, sunlight intensity—and array temperature. Operation anywhere on the current/voltage curve except at the optimal maximum-power-point voltage results in lowered efficiency and a waste of valuable energy. Consequently, methods for maximum-power-point tracking are common features in advanced solar-power-management systems because they can boost practical power-usage efficiency—often by 30% or more.

Because of its generality, a popular maximum-power-point-tracking-control algorithm is perturb and observe, which periodically modulates, or perturbs, the load voltage; calculates, or observes, the instantaneous transferred power response; and uses the phase relationship between load modulation and calculated power as feedback to “climb the hill” of the current/voltage curve to the maximum-power-point optimum. The perturb-and-observe algorithm is the basis of the maximum-power-point-tracking-control circuit (Figure 2, in yellow) but with a twist (in blue), which achieves a feedback function equivalent to a current-times-voltage power calculation but without the complexity of a conventional multiplier. The idea relies on the well-known logarithmic behavior of transistor junctions,

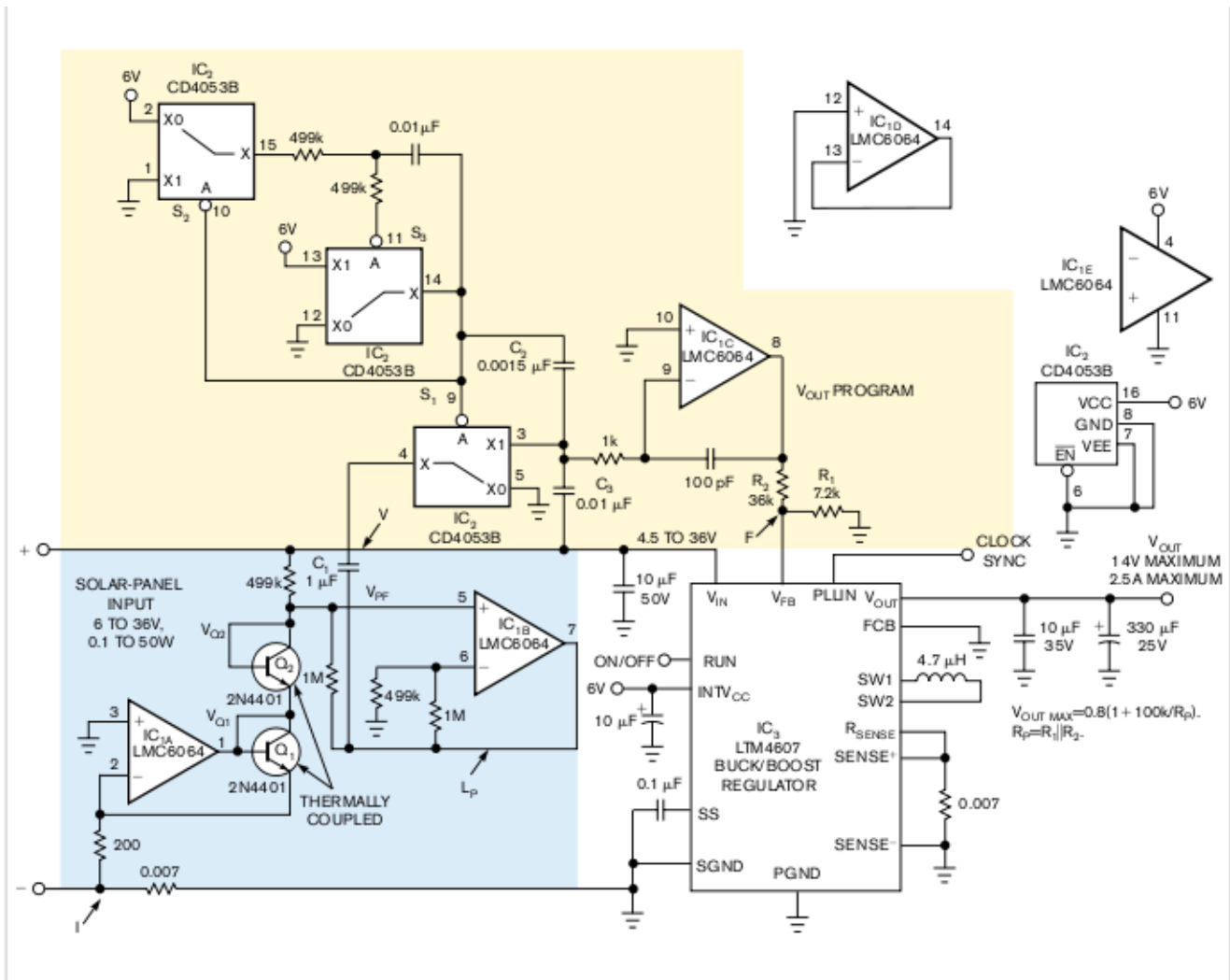

Figure 2. This maximum-power-point-tracking controller relies on the well-known logarithmic behavior of transistor junctions.

$V_{BE} = (kT/q) \log(I_C/I_S) = (kT/q) [\log(I_C) - \log(I_S)]$, where V_{BE} is the base-to-emitter voltage. It also relies on the fact that adding logarithms is mathematically equivalent to multiplication. Here's how.

Capacitor C_2 couples a 100-Hz, approximately 1V-p-p-modulation or 1V-p-p-perturbation square wave from the S_2/S_3 CMOS oscillator onto the photovoltaic-input voltage, V . The current/voltage curve of the array causes the input current, I , to reflect the V modulation with a corresponding voltage-times-current input-power modulation. IC_{1A} forces I_{Q1} to equal $I \times x_1$, where I is the solar-array current and x_1 is a gain constant. IC_{1B} forces I_{Q2} to equal $V/499 \text{ k}\Omega$, where V is the solar-array voltage. Thus, $V_{Q1} = (kT_1/q) I [\log(I) - \log(I_{S1}) + \log(x_1)]$, and $V_{Q2} = (kT_2/q) [\log(V) - \log(I_{S2}) - \log(499 \text{ k}\Omega)]$. V_{Q1} is the base-to-emitter voltage of Q_1 ; k is the Boltzman constant; T_1 is the temperature of Q_1 ; q is the elementary charge of the electron; I is the current input from the solar panel's negative terminal; I_{S1} is the saturation current of Q_1 ; x_1 is the arbitrary gain constant, which IC_3 determines; V is the voltage input from the solar panel's positive terminal; I_{S2} is the saturation current of Q_2 ; K is degrees Kelvin; V_{PF} is the power-feedback signal; and V_{IP} is the calculated power-input signal. Because k , q , I_{S1} , I_{S2} , x_1 , and $499 \text{ k}\Omega$ are all constants and $T_1 = T_2 = T$, however, for the purposes of the perturb-and-observe

algorithm, which is interested only in observing the variation of current and voltage with perturbation, effectively, $V_{Q1}=(kT/q)\log(I)$, and $V_{Q2}=(kT/q)\log(V)$.

The series connection of Q_1 and Q_2 yields $V_{PF}=V_{Q1}+V_{Q2}=(kT/q)[\log(I)+\log(V)]=(kT/q)\log(VI)$, and, because of IC_{1B} 's noninverting gain of three, $V_{IP}=3(kT/q)\log(VI)\approx 765 \mu V/\%$ of change in watts. The $V_{IP} \log(\text{power})$ signal couples through C_1 to synchronous demodulator S_1 , and error integrator and control op-amp IC_{1C} integrates the rectified S_1 output on C_3 . The IC_{1C} integrated error signal closes the feedback loop around the IC_3 regulator and results in the desired maximum-power-point-tracking behavior.

Using micropower parts and design techniques holds the total power consumption of the maximum-power-point-tracking circuit to approximately 1 mW, which avoids significantly eroding the efficiency advantage—the point of the circuit in the first place. Meanwhile, simplifying the interface between the maximum-power-point-tracking circuit and the regulator to only three connection nodes—I, V, and F—means that you can easily adapt the universal maximum-power-point-tracking circuit to most switching regulators and controllers. Therefore, this Design Idea offers the efficiency advantages of a maximum-power-point-tracking circuit to small solar-powered systems in which more complex, costly, and power-hungry implementations would be difficult to justify.